

## DN750 Dredge Ball Joint

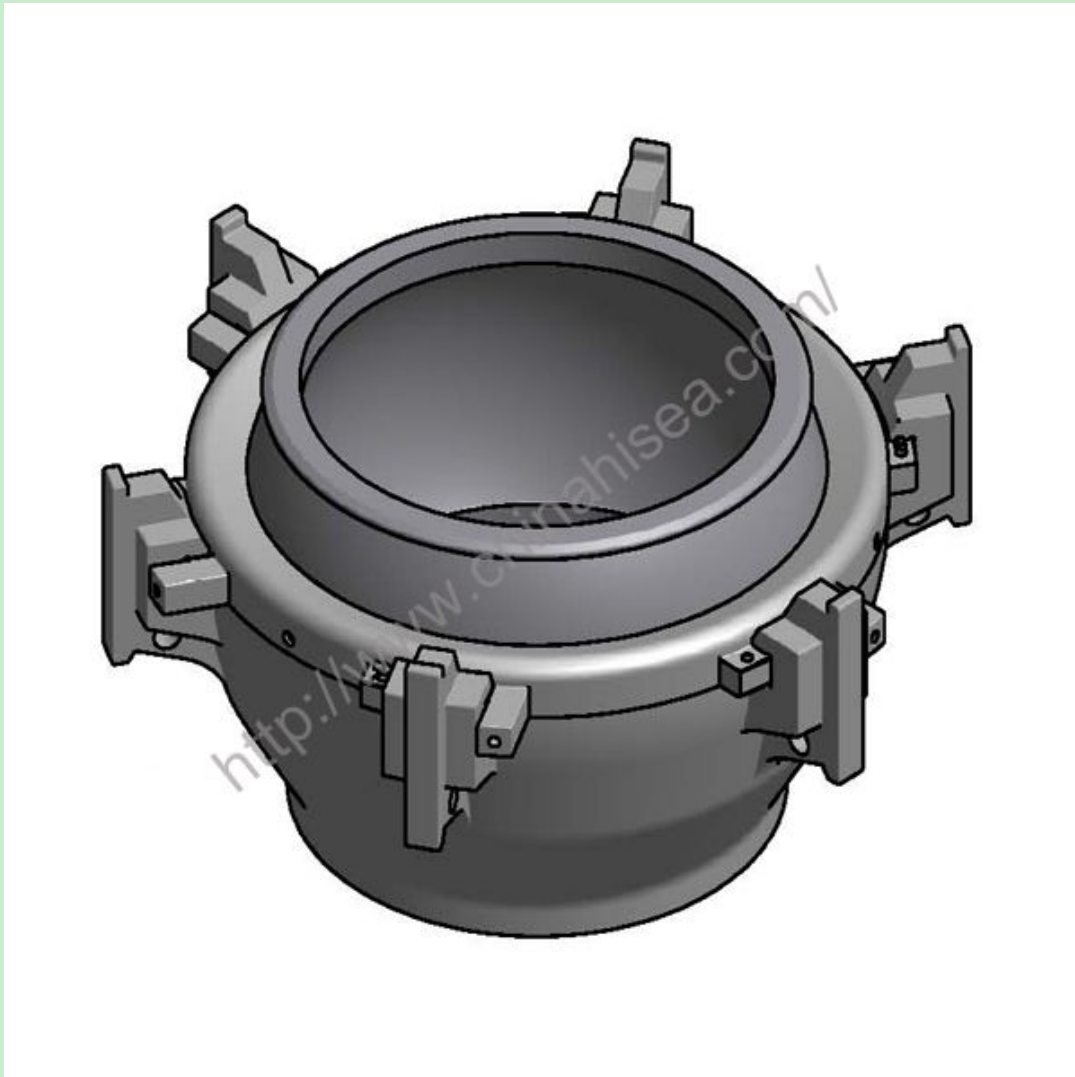

### DN750 dredge ball joint key features:

1. Pipe through ball construction
2. Ball joint to be welded to the dredge pipe
3. Exchangeable case liner
4. Exchangeable rubber seal
5. Ball joint can be customized to client' s requirements

### Technical Specifications

Dredge pipe(ID)	Max. Width	Height	Finished weight	Tilting angle
750mm	1550mm	1100mm	approx. 2300kg	15°

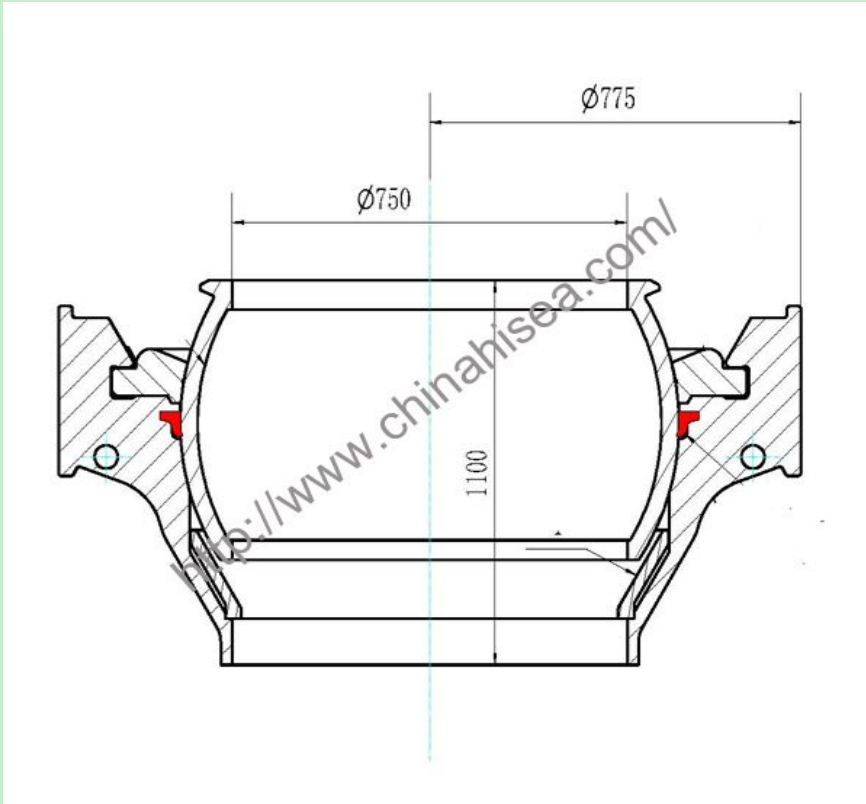

DN750 dredge ball joint drawing

**Materials used:**

Ball:	ZG30Mn
Case:	ZG30Mn
Gland:	ZG30Mn
Liner:	ZG30Mn
Seal:	NBR
Lock:	Q345

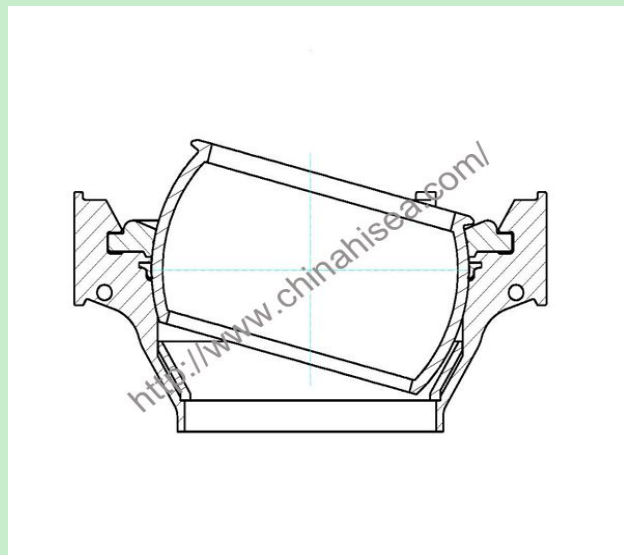

15° DN750 dredge ball joint

**Chongqing Hi-Sea Marine Equipment Import&Export Co.,Ltd.**

**Address:** 20-5, General Chamber of Commerce Building, No.2 Hongjin Street, Yubei District, Chongqing, China

**Email:** machine@hiseamarine.com mitang0708@foxmail.com **Skype:** cncqtang **QQ:** 2278612160

**TEL:** +86-23-67032301 **FAX:** +86-23-67955123 **Mobile:** +86-18108354610 **Post Code:** 401147

**Website:** www.hiseamarine.com www.chinahisea.com