

## Double-walled Dredge Pump

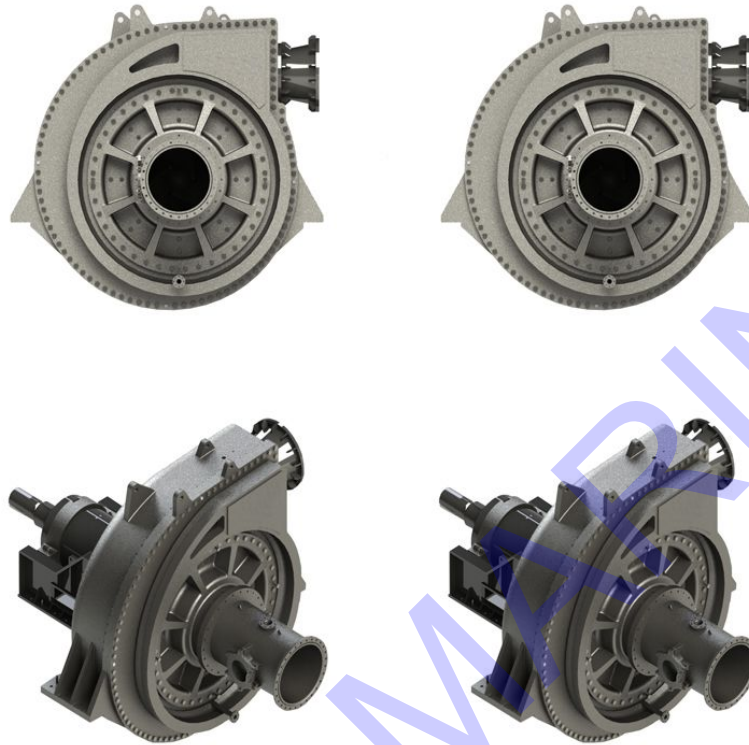

### Introduction of Double-walled Dredge Pump:

Double-walled dredge pumps stand for quality and reliability. Because of the own design can offer the ideal dredge pump for every need and situation. Our range of dredge pumps is based on three dredge pump types: submerged low pressure, inboard medium pressure, and inboard high pressure.

The minimal amount of wear parts in these dredge pumps lead to low wear, long life and lower maintenance which translates into reduced downtime and significant cost savings.

To accomplish these goals for the wear parts only very high quality, wear-resistant, materials with a hardness above 60HRC are used.

The dredging pumps are specially developed for the dredging industry and tailored to your specific needs and requirements. All dredge pump designs comply with the client's specific requirements, e.g.:

1. 3, 4 or 5 blade impeller
2. Low pressure, Medium pressure, High pressure
3. Water seal
4. Sealing and flushing water pumps
5. Wear-resistant material , hardness above 60HRc.

More options are available.

### Technical Specifications

Type	CAPACITY (m <sup>3</sup> /h)	HEAD (m)	IMPELLER SPEED (r/min)	EFFICIENCY (%)	INLET DIAMETER (mm)	OUTLET DIAMETER (mm)	NPSHR (m)	WEIGHT (ton)
100WS	180-250	25-45	1000-1400	50-58	150	100	<3.5	0.5
150WSG	350-700	40-65	800-980	68-71	200	150	<3.5	1.9
200WS	350-700	20-45	700-980	60-65	250	200	<4.5	2.3
200WSG	550-1000	40-65	700-850	70-72	250	200	<4	3.2
250WSG	900-1500	40-60	500-650	70-74	350	250	<4.5	4.6
300WSG	1500-2200	30-65	400-550	74-78	450	300	<4	8.0
450WSG	3000-4000	35-67	350-500	76-80	600	450	<4.5	12
500WSG	4000-5500	40-65	350-450	78-80	650	500	<4.8	17
600WSG	5000-9000	55-80	320-400	81-85	650	600	<6	35
800WSG	10000-15000	50-70	260-360	79-80	850	800	<6	58
900WSG	12000-19000	50-75	280-330	83-85	950	900	<6	85
1000WSG	16000-25000	23-76	180-290	85-87	1100	1000	<6	126

**NOTE:** According to user's or design and manufacturing drawing.



double-walled dredge pump in factory



double-walled dredge pump on the dredger

**Chongqing Hi-Sea Marine Equipment Import&Export Co.,Ltd.**

**Address:** 20-5,General Chamber of Commerce Building, No.2 Hongjin Street, Yubei District, Chongqing, China

**Email:** machine@hiseamarine.com mitang0708@foxmail.com **Skype:** cncqtang **QQ:** 2278612160

**TEL:** +86-23-67032301 **FAX:**+86-23-67955123 **Mobile:** +86-18108354610 **Post Code:**401147

**Website:** www.hiseamarine.com www.chinahisea.com