

### DIN 2627 Welding Neck Flange PN400

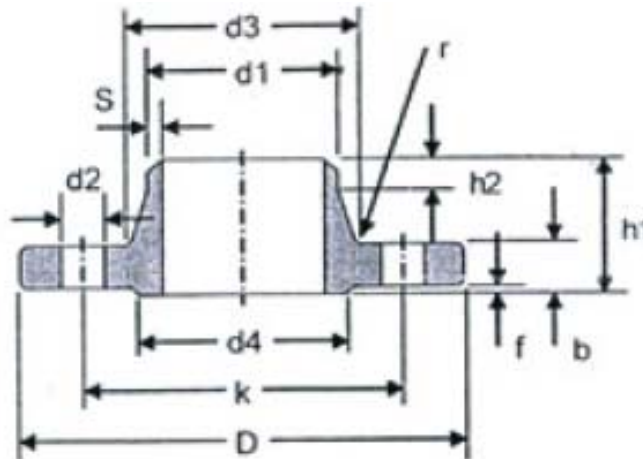

DN	d1		D	b	k	h1	d3	S	r	h2	d4	f	No. of holes	d2	KG
	ISO	DIN													
10	17.2	125	28	85	65	48	3.6	4	8	40	2	4	18	2.50	10
15	26.9	145	30	100	68	56	5.0	4	8	45	2	4	22	3.57	15
25	42.4	180	38	130	90	82	7.1	4	10	68	2	4	26	7.35	25
40	60.3	220	48	165	110	106	10.0	6	12	88	3	4	30	13.93	40
50	76.1	235	52	180	120	120	12.5	6	15	102	3	8	30	16.50	50
65	101.6	290	64	225	135	158	16.0	6	18	122	3	8	33	31.33	65
80	114.3	305	68	240	150	174	17.5	8	20	138	3	8	33	37.99	80
100	139.7	370	80	295	175	215	22.2	8	25	162	3	8	39	66.77	100
125	193.7	415	92	340	200	258	30.0	8	30	188	3	12	39	94.73	125
150	219.1	475	105	390	225	302	35.0	10	35	218	3	12	42	144.85	150
200	273.0	585	130	490	280	388	40.0	10	40	285	3	16	48	269.50	200

**DIN 2628 Welding Neck Flange PN250**

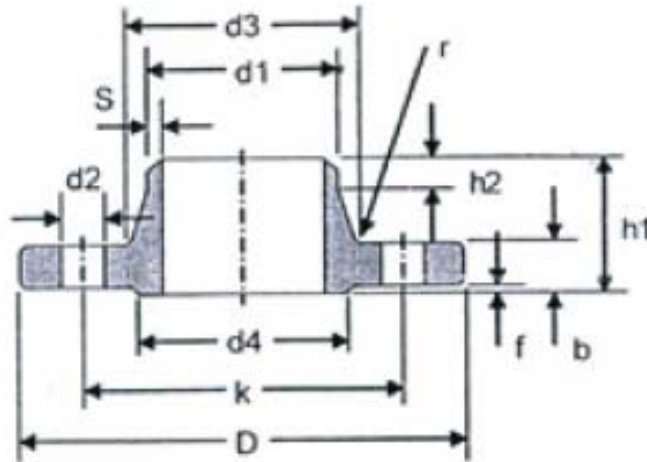

DN	d1		D	b	k	h1	d3	S	r	h2	d4	f	No. of holes	d2	KG
	ISO	DIN													
10	-	14	125	24	85	58	44	2.6	4	6	40	2	4	18	2.10
	17.2	-	125	24	85	58	44	2.6	4	6	40	2	4	18	2.09
15	-	20	130	26	90	60	48	2.6	4	6	45	2	4	18	2.48
	21.3	-	130	26	90	60	48	2.6	4	6	45	2	4	18	2.47
25	-	30	150	28	105	65	60	3.6	4	8	68	2	4	22	3.56
	33.7	-	150	28	105	65	60	3.6	4	8	68	2	4	22	3.53
40	-	44.5	185	34	135	80	84	5.0	6	10	88	3	4	26	6.65
	48.3	-	185	34	135	80	84	5.0	6	10	88	3	4	26	6.58
50	-	57	200	38	150	85	95	6.3	6	10	102	3	8	26	8.17
	60.3	-	200	38	150	85	95	6.3	6	10	102	3	8	26	8.09
65	76.1	-	230	42	180	95	124	8.0	6	12	122	3	8	26	12.59
80	101.6	-	255	46	200	102	136	11.0	8	12	138	3	8	30	16.32
100	127.0	-	300	54	235	120	164	14.2	8	14	162	3	8	33	27.07
125	152.4	-	340	60	275	140	200	16.0	8	16	188	3	12	33	38.79
150	177.8	-	390	68	320	160	240	17.5	10	18	218	3	12	36	59.05
200	244.5	-	485	82	400	190	305	25.0	10	25	285	3	12	42	109.45
250	298.5	-	585	100	490	215	385	32.0	12	30	345	3	16	48	189.94

### DIN 2629 Welding Neck Flange PN320

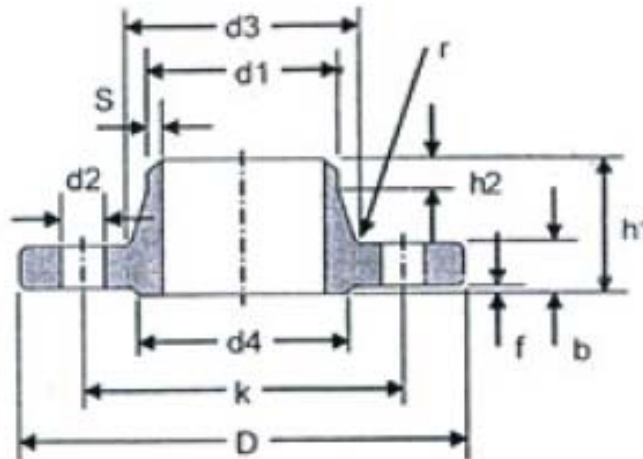

DN	d1		D	b	k	h1	d3	S	r	h2	d4	f	No. of holes	d2	KG
	ISO	DIN													
10.0	-	14	125	24	85	58	44	2.6	4	6	40	2	4	18.00	2.10
	17.2	-	125	24	85	58	44	2.6	4.0	6	40	2	4	18	2.09
15.0	-	20	130	26	90	60	48	3.2	4	6	45	2	4	18.00	2.49
	21.3	-	130	26	90	60	48	3.2	4.0	6	45	2	4	18	2.49
25.0	-	30	160	34	115	78	68	5.0	4	8	68	2	4	22.00	5.14
	33.7	-	160	34	115	78	68	5	4.0	8	68	2	4	22	5.11
40.0	-	44.5	195	38	145	88	92	6.3	6	10	88	3	4	26.00	8.53
	45.3	-	195	38	145	88	92	6.3	6.0	10	88	3	4	26	8.47
50.0	63.5	-	210	42	160	100	106	8.0	6	10	102	3	8	26.00	10.52
65.0	88.9	-	255	51	200	120	138	11.0	6	12	122	3	8	30.00	19.26
80.0	101.6	-	275	55	220	130	156	12.5	8	14	138	3	8	30.00	24.81
100.0	-	133	335	65	265	145	186	16.0	8	16	162	3	8	36.00	42.18
125.0	-	159	380	75	310	175	230	20.0	8	20	188	3	12	36.00	64.55
	168.3	-	380	75	310	175	230	20	8.0	20	188	3	12	36	63.30
150.0	193.7	-	425	84	350	195	265	25.0	10	25	218	3	12	36.00	91.04
175.0	219.1	-	485	95	400	215	308	28.0	10	28	260	3	12	42.00	135.46
200.0	244.5	-	525	103	440	235	345	30.0	10	30	285	3	16	42.00	170.94
250.0	323.9	-	640	125	540	300	428	40.0	12	40	345	3	16	52.00	311.99

### DIN 2630 Welding Neck Flange PN2.5

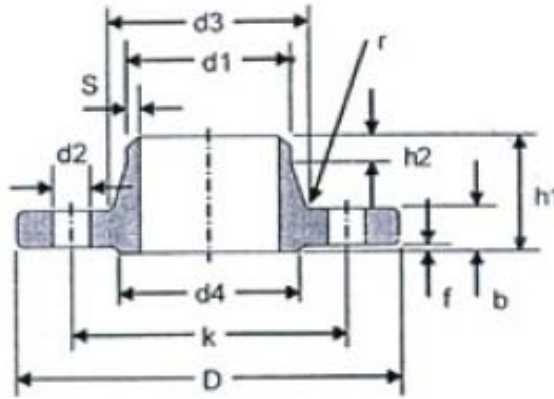

DN	ISO	DIN	D	b	k	h1	D3	S	r	h2	d4	f	No. of Holes	d2	KG
10	-	14	75	12	50	28	22	1.8	4	6	35	2	4	11	0.34
	17.2	-	75	12	50	28	26	1.8	4	6	35	2	4	11	0.34
15	-	20	80	12	55	30	28	2	4	6	40	2	4	11	0.39
	21.3	-	80	12	55	30	30	2	4	6	40	2	4	11	0.46
20	-	25	90	14	65	32	35	2.3	4	6	50	2	4	11	0.6
	26.9	-	90	14	65	32	38	2.3	4	6	50	2	4	11	0.6
25	-	30	100	14	75	35	40	2.6	4	6	60	2	4	11	0.78
	33.7	-	100	14	75	35	42	2.6	4	6	60	2	4	11	0.78
32	-	38	120	14	90	35	50	2.6	6	6	70	2	4	14	1.07
	42.4	-	120	14	90	35	55	2.6	6	6	70	2	4	14	1.06
40	-	44.5	130	14	100	38	55	2.6	6	7	80	3	4	14	1.21
	48.3	-	130	14	100	38	62	2.6	6	7	80	3	4	14	1.2
50	-	57	140	14	110	38	70	2.9	6	8	90	3	4	14	1.37
	60.3	-	140	14	110	38	74	2.9	6	8	90	3	4	14	1.36
65	76.1	-	160	14	130	38	88	2.9	6	9	110	3	4	14	1.6
80	88.9	-	190	16	150	42	102	3.2	8	10	128	3	4	18	2.72
100	-	106	210	16	170	45	122	3.6	8	10	148	3	4	18	3.2
	114.3	-	210	16	170	45	130	3.6	8	10	148	3	4	18	3.22
125	-	133	240	18	200	48	148	4	8	10	178	3	8	18	4.58
	139.7	-	240	18	200	48	155	4	8	10	178	3	8	18	4.42
150	-	159	265	18	225	48	172	4.5	10	12	202	3	8	18	5.26
	166.3	-	265	18	225	48	184	4.5	10	12	202	3	8	18	5.04
200	219.1	-	320	20	280	55	236	5.9	10	15	258	3	8	18	7.95
250	-	267	375	22	335	60	282	6.3	12	15	312	3	12	18	11.16
	273	-	375	22	335	60	290	6.3	12	16	312	3	12	18	10.57
300	323.9	-	440	22	395	62	342	7.1	12	15	365	4	12	22	14.26
350	355.6	-	490	22	445	62	385	7.1	12	15	415	4	12	22	18.56
	-	368	490	22	445	62	385	7.1	12	15	415	4	12	22	16.76
400	406.4	-	540	22	495	65	438	7.1	12	15	465	4	16	22	21.25
	-	419	540	22	495	65	438	7.1	12	15	465	4	16	22	19.1

### DIN 2631 Welding Neck Flange PN6

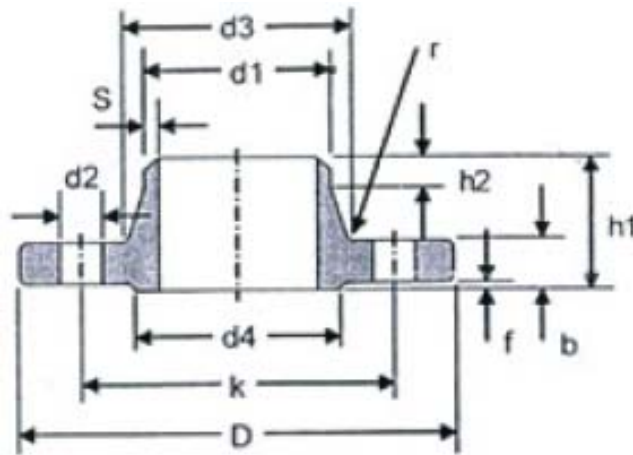

DN	d1		D	b	k	h1	d3	S	r	h2	d4	f	No. of holes	d2	KG
	ISO	DIN													
10	-	14	75	12	50	28	22	1.8	4	6	35	2	4	11	0.34
	17.2	-	75	12	50	28	26	1.8	4	6	35	2	4	11	0.34
15	-	20	80	12	55	30	28	2	4	6	40	2	4	11	0.39
	21.3	-	80	12	55	30	30	2	4	6	40	2	4	11	0.4
20	-	25	90	14	65	32	35	2.3	4	6	50	2	4	11	0.6
	26.9	-	90	14	65	32	38	2.3	4	6	50	2	4	11	0.6
25	-	30	100	14	75	35	40	2.6	4	6	60	2	4	11	0.76
	33.7	-	100	14	75	35	42	2.6	4	6	60	2	4	11	0.75
32	-	38	120	14	90	35	50	2.6	6	6	70	2	4	14	1.07
	42.4	-	120	14	90	35	55	2.6	6	6	70	2	4	14	1.06
40	-	44.5	130	14	100	38	58	2.6	6	7	80	3	4	14	1.21
	46.3	-	130	14	100	38	62	2.6	6	7	80	3	4	14	1.2
50	-	57	140	14	110	38	70	2.9	6	8	90	3	4	14	1.37
	60.3	-	140	14	110	38	74	2.9	6	8	90	3	4	14	1.36
65	76.1	-	160	14	130	38	88	2.9	6	9	110	3	4	14	1.69
80	88.9	-	190	16	150	42	102	3.2	8	10	128	3	4	18	2.72
100	-	108	210	16	170	45	122	3.6	8	10	148	3	4	18	3.29
	114.3	-	210	16	170	45	130	3.6	8	10	148	3	4	18	3.22
125	-	133	240	18	200	48	148	4	8	10	178	3	8	18	4.58
	139.7	-	240	18	200	48	155	4	8	10	178	3	8	18	4.42
150	-	159	265	18	225	48	172	4.5	10	12	202	3	8	18	5.26
	158.3	-	265	18	225	48	184	4.5	10	12	202	3	8	18	5.04
200	219.1	-	320	20	280	55	236	5.9	10	15	258	3	8	18	7.95
250	-	267	375	22	335	60	282	6.3	12	15	312	3	12	18	11.16
	273	-	375	22	335	60	290	6.3	12	15	312	3	12	18	10.87
300	323.9	-	440	22	395	62	342	7.1	12	15	365	4	12	22	14.26
350	355.6	-	490	22	445	62	385	7.1	12	15	415	4	12	22	18.54
	-	368	490	22	445	62	385	7.1	12	15	415	4	12	22	16.78
400	406.6	-	540	22	495	65	438	7.1	12	15	465	4	16	22	21.25
	-	419	540	22	495	65	438	7.1	12	15	465	4	16	22	19.1

### DIN 2632 Welding Neck Flange PN10

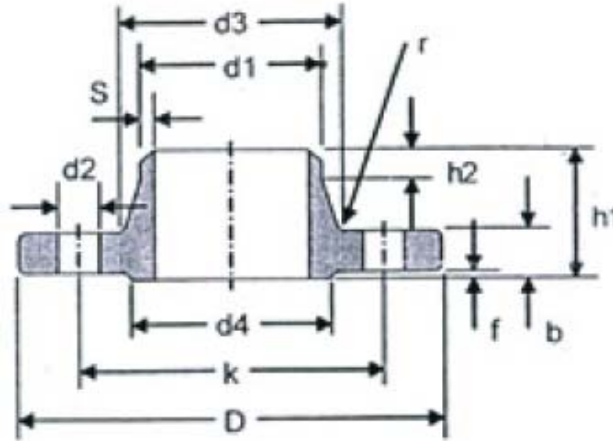

DN	d1		D	b	k	h1	d3	S	r	h2	d4	f	No. of holes	d2	KG
	ISO	DIN													
10	-	14	90	14	60	35	25	1.8	4	6	40	2	4	14	0.58
	17.2	-	90	14	60	35	28	1.8	4	6	40	2			
15	-	20	95	14	65	35	30	2	4	6	45	2	4	14	0.65
	21.3	-	95	14	65	35	32	2	4	6	45	2			
20	-	25	105	16	75	38	38	2.3	4	6	58	2	4	14	0.95
	26.9	-	105	16	75	38	40	2.3	4	6	58	2			
25	-	30	115	16	85	38	42	2.6	4	6	68	2	4	14	1.15
	33.7	-	115	16	85	38	45	2.6	4	6	68	2			
32	-	38	140	16	100	40	52	2.6	6	6	78	2	4	18	1.67
	42.4	-	140	16	100	40	55	2.6	6	6	78	2			
40	-	44.5	150	16	110	42	60	2.6	6	7	88	3	4	18	1.85
	48.3	-	150	16	110	42	64	2.6	6	7	88	3			
50	-	57	165	18	125	45	72	2.9	6	8	102	3	4	18	2.51
	60.3	-	165	18	125	45	75	2.9	6	8	102	3			
65	76.1	-	165	18	145	45	90	2.9	6	10	122	3	4	18	3.03
80	88.9	-	200	20	160	50	105	3.2	6	10	138	3	8	18	3.82
100	-	108	220	20	180	52	125	3.6	8	12	158	3	8	18	4.54
	114.3	-	220	20	180	52	131	3.6	8	12	158	3			
125	-	133	250	22	210	55	150	4	8	12	188	3	8	18	6.28
	139.7	-	250	22	210	55	156	4	8	12	188	3			
150	-	159	285	22	240	55	175	4.5	10	12	212	3	8	22	7.75
	168.3	-	285	22	240	55	184	4.5	10	12	212	3			
200	219.1	-	340	24	295	62	235	5.9	10	16	268	3	8	22	11.10
250	-	267	395	26	350	68	285	6.3	12	16	320	3	12	22	15.31
	273	-	395	26	350	68	292	6.3	12	16	320	3			
300	323.9	-	445	26	400	68	344	7.1	12	16	370	4	12	22	17.47
350	355.6	-	505	26	460	66	385	7.1	12	16	430	4	16	22	23.7
	-	368	505	26	460	68	385	7.1	12	16	430	4			
400	406.4	-	565	26	515	72	440	7.1	12	16	482	4	16	26	28.72
	-	419	565	26	515	72	440	7.1	12	16	482	4			

### DIN 2633 Welding Neck Flange PN16

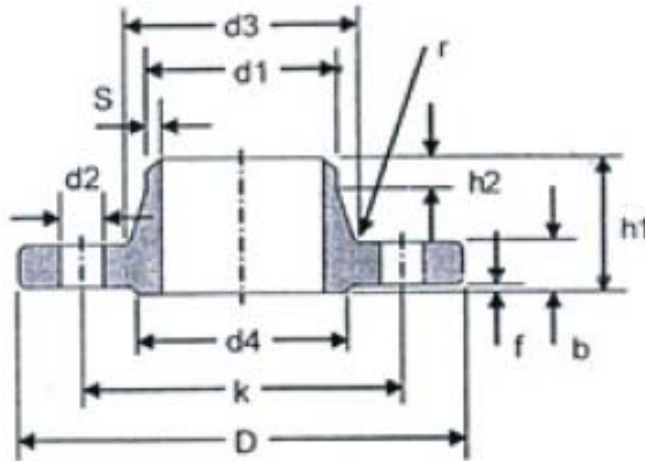

DN	d1		D	b	k	h1	d3	S	r	h2	d4	f	No. of holes	d2	KG
	ISO	DIN													
250	-	267	405	26	355	70	285	6.3	12	16	320	3	12	26	16.26
	273	-	405	26	355	70	292	6.3	12	16	320	3	12	26	15.87
300	323.9	-	460	28	410	78	344	7.1	12	16	378	4	12	26	21.24
350	355.6	-	520	30	470	82	390	8	12	16	438	4	16	26	31.38
	-	368	520	30	470	82	390	8	12	16	438	4	16	26	28.95
400	406.4	-	580	32	525	85	445	8	12	16	490	4	16	30	39.3
	-	419	580	32	525	85	445	8	12	16	490	4	16	30	36.3
500	508	-	715	34	650	90	548	8	12	16	610	4	20	33	59.63
600	610	-	840	36	770	95	652	8.8	12	18	725	5	20	36	82.54
700	711	-	910	36	840	100	755	8.8	12	18	795	5	24	36	83.9
800	813	-	1025	38	950	105	855	10	12	20	900	5	24	39	107.3
900	914	-	1125	40	1050	110	955	10	12	20	1000	5	28	39	124.97
1000	1016	-	1255	42	1170	120	1058	10	16	22	1115	5	28	42	163.76
1200	1220	-	1485	48	1390	130	1262	12.5	16	30	1330	5	32	48	244.15
1400	1420	-	1685	52	1590	145	1465	14.2	16	30	1530	5	36	48	320.87
1600	1620	-	1930	58	1820	160	1668	16	16	35	1750	5	40	56	465.83
1800	1820	-	2130	62	2020	170	1870	17.5	16	35	1950	5	44	56	570.52
2000	2020	-	2345	66	2230	180	2072	20	16	40	2150	5	48	62	706.74

### DIN 2634 Welding Neck Flange PN25

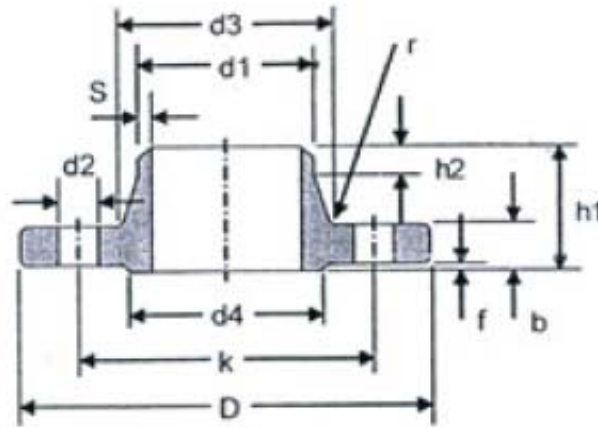

DN	d1		D	b	k	h1	d3	S	r	h2	d4	f	No. of holes	d2	KG
	ISO	DIN													
10	-	14	90	16	60	35	25	1.8	4	6	40	2	4	14	0.67
	17.2	-	90	16	60	35	28	1.8	4	6	40	2	4	14	0.66
15	-	20	95	16	65	38	30	2	4	6	45	2	4	14	0.75
	21.3	-	95	16	65	38	32	2	4	6	45	2	4	14	0.75
20	-	25	105	18	75	40	38	2.3	4	6	58	2	4	14	1.07
	26.9	-	105	18	75	40	40	2.3	4	6	58	2	4	14	1.07
25	-	30	115	18	85	40	42	2.6	4	6	68	2	4	14	1.29
	33.7	-	115	18	85	40	46	2.6	4	6	68	2	4	14	1.28
32	-	38	140	18	100	42	52	2.6	6	6	78	2	4	18	1.88
	42.4	-	140	18	100	42	56	2.6	6	6	78	2	4	18	1.86
40	-	44.5	150	18	110	45	60	2.6	6	7	88	3	4	18	2.1
	48.3	-	150	18	110	45	64	2.6	6	7	88	3	4	18	2.08
50	-	57	165	20	125	48	72	2.9	6	8	102	3	4	18	2.81
	60.3	-	165	20	125	48	75	2.9	6	8	102	3	4	18	2.78
65	76.1	-	185	22	145	52	90	2.9	6	10	122	3	8	18	3.61
80	88.9	-	200	24	160	58	105	3.2	8	12	138	3	8	18	4.62
100	-	106	235	24	190	65	128	3.6	8	12	162	3	8	22	6.42
	114.3	-	235	24	190	65	134	3.6	8	12	162	3	8	22	6.27
125	-	133	270	26	220	68	155	4	8	12	188	3	8	26	8.83
	139.7	-	270	26	220	68	162	4	8	12	188	3	8	26	8.61
150	-	159	300	28	250	75	182	4.5	10	12	218	3	8	26	11.67
	166.3	-	300	28	250	75	192	4.5	10	12	218	3	8	26	11.29
175	193.7	-	330	28	280	75	218	5.6	10	15	248	3	12	26	13.11
200	219.1	-	360	30	310	80	244	6.3	10	16	278	3	12	26	16.61
250	-	267	425	32	370	88	292	7.1	12	18	335	3	12	30	23.99
	273	-	425	32	370	88	298	7.1	12	18	335	3	12	30	23.48
300	323.9	-	485	34	430	92	352	8	12	18	395	4	16	30	30.74
350	355.6	-	555	38	490	100	398	8	12	20	450	4	16	33	47.20
	-	368	555	38	490	100	398	8	12	20	450	4	16	33	44.22
400	406.4	-	620	40	550	110	452	8.8	12	20	505	4	16	36	61.69
	-	419	620	40	550	110	452	8.8	12	20	505	4	16	36	57.88
500	508	-	730	44	660	125	558	10	12	20	615	4	20	36	89.57
600	610	-	845	46	770	125	660	11	12	20	720	5	20	39	114.96
700	711	-	960	46	875	125	760	12.5	12	20	820	5	24	42	139.5
800	813	-	1085	50	990	135	865	14.2	12	22	930	5	24	48	188.71
900	914	-	1185	54	1090	145	968	16	12	24	1030	5	28	48	231.48
1000	1016	-	1320	58	1210	155	1070	17.5	16	24	1140	5	28	56	303.52



### DIN 2635 Welding Neck Flange PN40

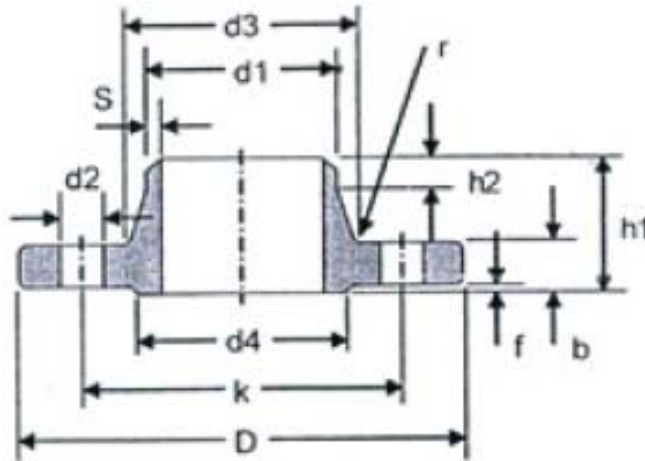

DN	d1		D	b	k	h1	d3	S	r	h2	d4	f	No. of holes	d2	KG
	ISO	DIN													
10	-	14	90	16	60	35	25	1.8	4	6	40	2	4	14	0.67
	17.2	-	90	16	60	35	28	1.8	4	6	40	2	4	14	0.66
15	-	20	95	16	65	38	30	2	4	6	45	2	4	14	0.75
	21.3	-	95	16	65	38	32	2	4	6	45	2	4	14	0.75
20	-	25	105	18	75	40	48	2.3	4	6	58	2	4	14	1.07
	26.9	-	105	18	75	40	40	2.3	4	6	58	2	4	14	1.07
25	-	30	115	18	85	40	42	2.6	4	6	68	2	4	14	1.29
	33.7	-	115	18	85	40	46	2.6	4	6	68	2	4	14	1.28
32	-	38	140	18	100	42	52	2.6	6	6	78	2	4	18	1.88
	42.4	-	140	18	100	42	56	2.6	6	6	78	2	4	18	1.86
40	-	44.5	150	18	110	45	60	2.6	6	7	88	3	4	18	2.1
	48.3	-	150	18	110	45	64	2.6	6	7	88	3	4	18	2.08
50	-	57	165	20	125	48	72	2.9	6	8	102	3	4	18	2.81
	60.3	-	165	20	125	48	75	2.9	6	8	102	3	4	18	2.78
65	76.1	-	185	22	145	52	90	2.9	6	10	122	3	8	18	3.81
80	88.9	-	200	24	160	58	105	3.2	8	12	138	3	8	18	4.62
100	-	108	235	24	190	65	128	3.8	8	12	162	3	8	22	6.42
	114.3	-	235	24	190	65	134	3.6	8	12	162	3	8	22	6.27
125	-	133	270	26	220	68	155	4	8	12	188	3	8	26	8.83
	139.7	-	270	26	220	68	162	4	8	12	188	3	8	26	8.61
150	-	159	300	28	250	75	182	4.5	10	12	218	3	8	26	11.67
	168.3	-	300	28	250	75	192	4.5	10	12	218	3	8	26	11.29
175	193.7	-	350	32	295	82	218	5.6	10	15	260	3	12	30	17.01
200	219.1	-	375	34	320	88	244	6.3	10	16	285	3	12	30	20.49
250	-	267	450	38	385	105	298	7.1	12	18	345	3	12	33	33.75
	273	-	450	38	385	105	306	7.1	12	18	345	3	12	33	33.34
300	323.9	-	515	42	450	115	362	8	12	18	410	4	16	33	46.55
350	355.6	-	580	46	510	125	408	8.8	12	20	465	4	16	36	67.73
	-	368	580	46	510	125	408	8.8	12	20	465	4	16	36	63.96
400	406.4	-	660	50	585	135	462	11	12	20	535	4	16	39	96.73
	-	419	660	50	585	135	462	11	12	20	535	4	16	39	91.99
500	508	-	755	52	670	140	562	14.2	12	20	615	4	20	42	120.96

### DIN 2636 Welding Neck Flange PN64

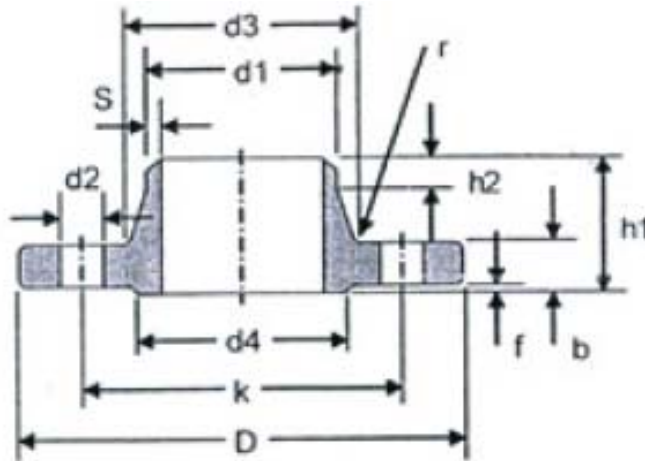

DN	d1		D	b	k	h1	d3	S	r	h2	d4	f	No. of holes	d2	KG
	ISO	DIN													
10	-	14	100	20	70	45	28	1.8	4	6	40	2	4	14	1.07
	17.2	-	100	20	70	45	32	1.8	4	6	40	2	4	14	1.08
15	-	20	105	20	75	45	32	2.0	4	6	45	2	4	14	1.19
	21.3	-	105	20	75	45	34	2.0	4	6	45	2	4	14	1.19
25	-	30	140	24	100	58	48	2.6	4	8	68	2	4	18	2.61
	33.7	-	140	24	100	58	52	2.6	4	8	68	2	4	18	2.60
40	-	44.5	170	26	125	62	65	2.9	6	10	88	3	4	22	4.00
	48.3	-	170	26	125	62	70	2.9	6	10	88	3	4	22	3.99
50	-	57	180	26	135	62	78	2.9	6	10	102	3	4	22	4.45
	60.3	-	180	26	135	62	82	2.9	6	10	102	3	4	22	4.42
65	76.1	-	205	26	160	66	98	3.2	6	12	122	3	8	22	5.49
80	88.9	-	215	28	170	72	112	3.6	8	12	138	3	8	22	6.50
100	-	108	250	30	200	76	132	4.0	8	12	162	3	8	26	9.25
	114.3	-	250	30	200	76	138	4.0	8	12	162	3	8	26	9.06
125	-	133	295	34	240	88	162	4.5	8	12	188	3	8	30	14.53
	139.7	-	295	34	240	88	168	4.5	8	12	188	3	8	30	14.23
150	-	159	345	36	280	95	192	5.6	10	12	218	3	8	33	21.35
	168.3	-	345	36	280	95	202	5.6	10	12	218	3	8	33	20.92
175	193.7	-	375	40	310	105	228	6.3	10	16	260	3	12	33	26.28
200	219.1	-	415	42	345	110	256	7.1	10	16	285	3	12	36	33.56
250	-	267	470	46	400	125	310	8.8	12	18	345	3	12	36	47.98
	273.0	-	470	46	400	125	316	8.8	12	18	345	3	12	36	47.32
300	323.9	-	530	52	460	140	372	11.0	12	18	410	4	16	36	66.44
350	355.6	-	600	56	525	150	420	12.5	12	20	465	4	16	39	96.23
	-	368	600	56	525	150	420	12.5	12	20	465	4	16	39	91.77
400	406.4	-	670	60	585	160	475	14.2	12	20	535	4	16	42	127.70
	-	419	670	60	585	160	475	14.2	12	20	535	4	16	42	122.13

### DIN 2637 Welding Neck Flange PN100

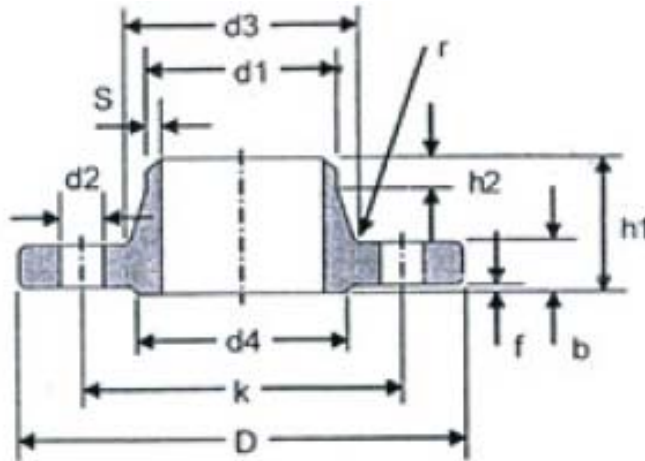

DN	d1		D	b	k	h1	d3	S	r	h2	d4	f	No. of holes	d2	KG
	ISO	DIN													
10	-	14	100	20	70	45	28	1.8	4	6	40	2	4	14	1.07
	17.2	-	100	20	70	45	32	1.8	4	6	40	2	4	14	1.08
15	-	20	105	20	75	45	32	2.0	4	6	45	2	4	14	1.19
	21.3	-	105	20	75	45	34	2.0	4	6	45	2	4	14	1.19
25	-	30	140	24	100	58	48	2.6	4	8	68	2	4	18	2.61
	33.7	-	140	24	100	58	52	2.6	4	8	68	2	4	18	2.60
40	-	44.5	170	26	125	62	65	2.9	6	10	88	3	4	22	4.00
	48.3	-	170	26	125	62	70	2.9	6	10	88	3	4	22	3.99
50	-	57	195	28	145	68	86	3.2	6	10	102	3	4	26	5.72
	60.3	-	195	28	145	68	90	3.2	6	10	102	3	4	26	5.70
65	76.1	-	220	30	170	76	108	3.6	6	12	122	3	8	26	7.43
80	88.9	-	230	32	180	78	120	4.0	8	12	138	3	8	26	8.58
100	-	108	265	36	210	90	145	5.0	8	12	162	3	8	30	13.02
	114.3	-	265	36	210	90	150	5.0	8	12	162	3	8	30	12.79
125	-	133	315	40	250	105	180	6.3	8	12	188	3	8	33	21.29
	139.7	-	315	40	250	105	180	6.3	8	12	188	3	8	33	20.68
150	-	159	355	44	290	115	210	7.1	10	12	218	3	12	33	28.90
	168.3	-	355	44	290	115	210	7.1	10	12	218	3	12	33	27.76
175	193.7	-	385	48	320	127	245	8.8	10	16	260	3	12	33	36.94
200	219.1	-	430	52	360	130	278	10.0	10	16	285	3	12	36	49.35
250	-	267	505	60	430	157	340	12.5	12	18	345	3	12	39	81.71
	273.0	-	505	60	430	157	340	12.5	12	18	345	3	12	39	80.09
300	323.9	-	585	68	500	170	400	14.2	12	18	410	4	16	42	116.25
350	355.6	-	655	74	560	189	460	16.0	12	20	465	4	16	48	166.09
	-	368	655	74	560	189	460	16.0	12	20	465	4	16	48	160.53

### DIN 2638 Welding Neck Flange PN160

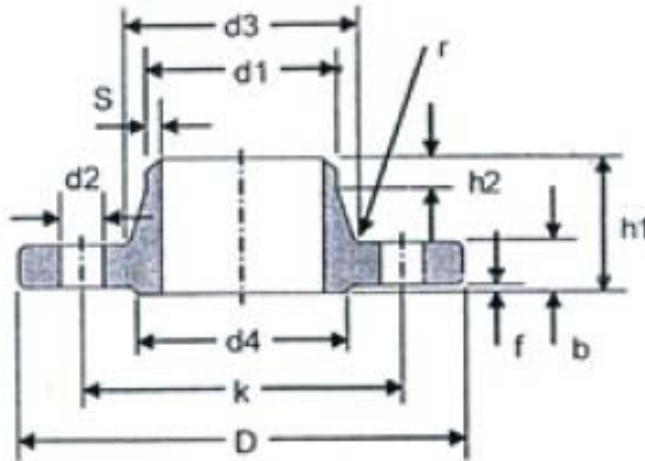

DN	d1		D	b	k	h1	d3	S	r	h2	d4	f	No. of holes	d2	KG
	ISO	DIN													
10	-	14	100	20	70	45	28	2.0	4	6	40	2	4	14	1.08
	17.2	-	100	20	70	45	32	2.0	4	6	40	2	4	14	1.08
15	-	20	105	20	75	45	32	2.0	4	6	45	2	4	14	1.19
	21.3	-	105	20	75	45	34	2.0	4	6	45	2	4	14	1.19
25	-	30	140	24	100	58	48	2.9	4	8	68	2	4	18	2.62
	33.7	-	140	24	100	58	52	2.9	4	8	68	2	4	18	2.62
40	-	44.5	170	28	125	64	65	3.6	6	10	88	3	4	22	4.36
	48.3	-	170	28	125	64	70	3.6	6	10	88	3	4	22	4.34
50	-	57	195	30	145	75	86	4.0	6	10	102	3	4	26	6.28
	60.3	-	195	30	145	75	90	4.0	6	10	102	3	4	26	6.27
65	76.1	-	220	34	170	82	108	5.0	6	12	122	3	8	26	8.61
80	88.9	-	230	36	180	86	120	6.3	8	12	138	3	8	26	10.09
100	-	108	265	40	210	100	145	8.0	8	12	162	3	8	30	15.28
	114.3	-	265	40	210	100	150	8.0	8	12	162	3	8	30	15.07
125	-	133	315	44	250	115	180	10.0	8	14	188	3	8	33	24.68
	139.7	-	315	44	250	115	180	10.0	8	14	188	3	8	33	24.09
150	-	159	355	50	290	128	210	12.5	10	14	218	3	12	33	35.14
	168.3	-	355	50	290	128	210	12.5	10	14	218	3	12	33	34.02
175	193.7	-	390	54	320	138	245	14.2	10	16	260	3	12	36	44.90
200	219.1	-	490	60	360	140	278	16.0	10	16	285	3	12	36	60.03
250	-	267	515	68	430	155	340	20.0	12	18	345	3	12	42	98.05
	273	-	515	68	430	155	340	20.0	12	18	345	3	12	42	96.52
300	323.9	-	585	76	500	175	400	22.2	12	18	410	4	16	42	138.80