

# ASTM A182 FLANGES ANSI B16.5 INDEX

<b>CLASS 150 STAINLESS STEEL FLANGES ANSI B16.5</b> .....	<b>2</b>
<b>CLASS 150 STAINLESS STEEL FLANGES ANSI B16.5</b> .....	<b>3</b>
<b>CLASS 300 STAINLESS STEEL FLANGES ANSI B16.5</b> .....	<b>4</b>
<b>CLASS 300 STAINLESS STEEL FLANGES ANSI B16.5</b> .....	<b>5</b>
<b>CLASS 600 STAINLESS STEEL FLANGES ANSI B16.5</b> .....	<b>6</b>
<b>CLASS 600 STAINLESS STEEL FLANGES ANSI B16.5</b> .....	<b>7</b>

# ASTM A182 FLANGES ANSI B16.5

## CLASS 150 STAINLESS STEEL FLANGES ANSI B16.5

### WELDING NECK

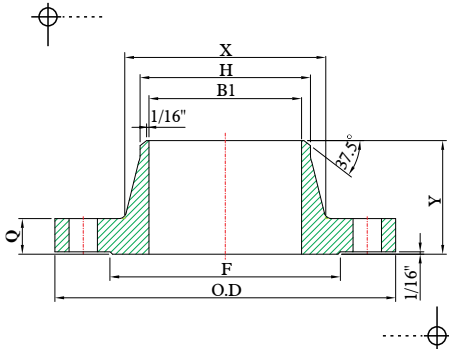

### LAP JOINT

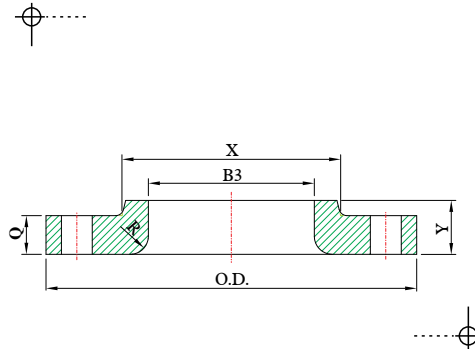

### SLIP-ON

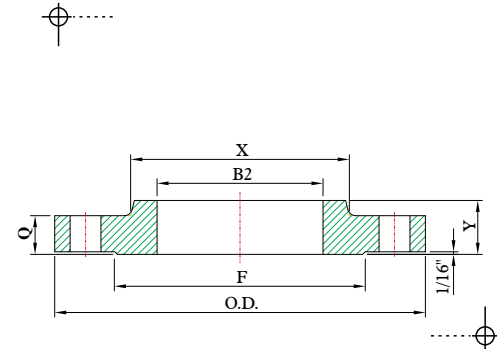

## DIMENSIONS

unit : inch

NOM. PIPE SIZE	FLANGE DIAMETER (O.D.)	FLANGE THICKNESS (Q) MIN. (1)	HUB DIA. AT BASE (X)	RAISED FACE DIA. (F)	HUB DIA. AT WELDING POINT (H)	BORE DIAMETER (B)			COUNTER BORE OF THREADED FLANGE (C)	DEPTH OF SOCKET (D)	LENGTH THROUGH HUB (Y)		
						(B1) WELDING NECK AND SOCKET WELD (2)	(B2) SLIP-ON AND SOCKET WELD MIN.	(B3) LAP JOINT MIN.			WELDING NECK	SLIP-ON SOCKET WELD AND THREADED	LAP JOINT
1/2	3.50	0.44	1.19	1.38	0.84	0.62	0.88	0.90	NO COUNTER BORE REQUIRED ON 150# THREADED FLANGES	0.38	1.88	0.62	0.62
3/4	3.88	0.50	1.50	1.69	1.05	0.82	1.09	1.11		0.44	2.06	0.62	0.62
1	4.25	0.56	1.94	2.00	1.32	1.05	1.36	1.38		0.50	2.19	0.69	0.69
1 1/4	4.62	0.62	2.31	2.50	1.66	1.38	1.70	1.72		0.56	2.25	0.81	0.81
1 1/2	5.00	0.69	2.56	2.88	1.90	1.61	1.95	1.97		0.62	2.44	0.88	0.88
2	6.00	0.75	3.06	3.62	2.38	2.07	2.44	2.46		0.69	2.50	1.00	1.00
2 1/2	7.00	0.88	3.56	4.12	2.88	2.47	2.94	2.97		0.75	2.75	1.12	1.12
3	7.50	0.94	4.25	5.00	3.50	3.07	3.57	3.60		0.81	2.75	1.19	1.19
3 1/2	8.50	0.94	4.81	5.50	4.00	3.55	4.07	4.10		0.88	2.81	1.25	1.25
4	9.00	0.94	5.31	6.19	4.50	4.03	4.57	4.60		0.94	3.00	1.31	1.31
5	10.00	0.94	6.44	7.31	5.56	5.05	5.66	5.69		0.94	3.50	1.44	1.44
6	11.00	1.00	7.56	8.50	6.63	6.07	6.72	6.75		1.06	3.50	1.56	1.56
8	13.50	1.12	9.69	10.62	8.63	7.98	8.72	8.75		1.25	4.00	1.75	1.75
10	16.00	1.19	12.00	12.75	10.75	10.02	10.88	10.92		1.31	4.00	1.94	1.94
12	19.00	1.25	14.38	15.00	12.75	12.00	12.88	12.92		1.56	4.50	2.19	2.19
14	21.00	1.38	15.75	16.25	14.00	13.25	14.14	14.18		1.63	5.00	2.25	3.12
16	23.50	1.14	18.00	18.50	16.00	15.25	16.16	16.19	1.75	5.00	2.50	3.44	
18	25.00	1.56	19.88	21.00	18.00	17.25	18.18	18.20	1.94	5.50	2.69	3.81	
20	27.50	1.69	22.00	23.00	20.00	19.25	20.20	20.25	2.12	5.69	2.88	4.06	
24	32.00	1.88	26.12	27.25	24.00	23.25	24.25	24.25	2.50	6.00	3.25	4.38	

# ASTM A182 FLANGES ANSI B16.5

## CLASS 150 STAINLESS STEEL FLANGES ANSI B16.5

### THREADED

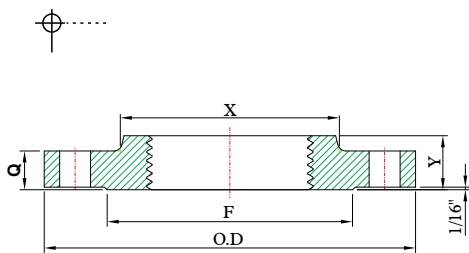

### BLIND

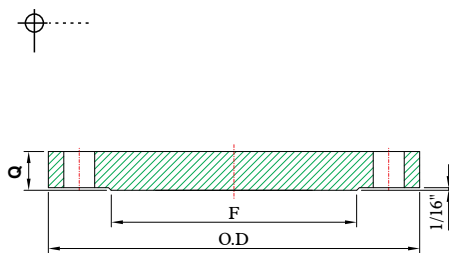

### SOCKET WELD

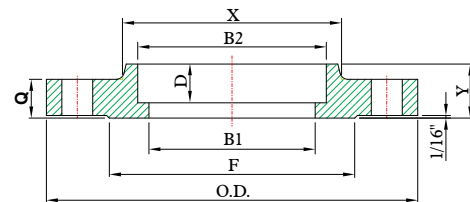

## DIMENSIONS

unit : inch

NOM. PIPE SIZE	MIN. THREAD LENGTH	RADIUS (R) LAP JOINT	DRILLING			BOLTING			
			DIAMETER OF BOLT CIRCLE	NO. OF HOLES	DIA. OF HOLES	DIA. OF BOLTS	MACHINE BOLT LENGTH	STUD BOLT LENGTH	
								Raised Face .06"	Ring Joint
1/2	0.62	0.12	2.38	4	0.62	1/2	2.00	2.50	-
3/4	0.62	0.12	2.75	4	0.62	1/2	2.25	2.50	-
1	0.69	0.12	3.12	4	0.62	1/2	2.25	2.75	3.25
1 1/4	0.81	0.19	3.50	4	0.62	1/2	2.50	2.75	3.25
1 1/2	0.88	0.25	3.88	4	0.62	1/2	2.50	3.00	3.50
2	1.00	0.31	4.75	4	0.75	5/8	2.75	3.25	3.75
2 1/2	1.12	0.31	5.50	4	0.75	5/8	3.00	3.50	4.00
3	1.19	0.38	6.00	4	0.75	5/8	3.25	3.75	4.25
3 1/2	1.25	0.38	7.00	8	0.75	5/8	3.25	3.75	4.25
4	1.31	0.44	7.50	8	0.75	5/8	3.25	3.75	4.25
5	1.44	0.50	8.50	8	0.88	3/4	3.25	4.00	4.50
6	1.56	0.50	9.50	8	0.88	3/4	3.50	4.00	4.50
8	1.75	0.50	11.75	8	0.88	3/4	3.75	4.25	4.75
10	1.94	0.50	14.25	12	1.00	7/8	4.00	4.75	5.25
12	2.19	0.50	17.00	12	1.00	7/8	4.25	4.75	5.25
14	2.25	0.50	18.75	12	1.12	1	4.50	5.25	5.75
16	2.50	0.50	21.25	16	1.12	1	4.75	5.50	6.00
18	2.69	0.50	22.75	16	1.25	1 1/8	5.00	6.00	6.50
20	2.88	0.50	25.00	20	1.25	1 1/8	5.50	6.25	6.75
24	3.25	0.50	29.50	20	1.38	1 1/4	6.00	7.00	7.50

NOM. PIPE SIZE	APPROXIMATE WEIGHT EACH— POUNDS ±			
	WELDING NECK	SLIP-ON. SOCKET WELD AND THREADED	LAP JOINT	BLIND
1/2	1.25	1.00	1.00	1.25
3/4	2.00	1.50	1.50	1.50
1	2.50	2.00	2.00	2.00
1 1/4	3.00	3.00	3.00	3.00
1 1/2	4.50	3.00	3.50	4.00
2	6.00	5.25	5.00	6.50
2 1/2	10.00	8.00	7.00	9.50
3	12.00	9.00	9.25	12.50
3 1/2	12.00	11.00	11.00	13.00
4	16.50	12.50	12.50	17.00
5	19.00	15.00	15.00	20.00
6	25.00	19.00	19.00	26.50
8	39.00	30.00	30.00	45.00
10	52.00	43.00	43.00	70.00
12	80.00	64.00	64.00	110.00
14	110.00	90.00	105.00	140.00
16	140.00	98.00	140.00	180.00
18	150.00	130.00	160.00	220.00
20	180.00	165.00	195.00	285.00
24	260.00	220.00	275.00	430.00

# ASTM A182 FLANGES ANSI B16.5

## CLASS 300 STAINLESS STEEL FLANGES ANSI B16.5

### WELDING NECK

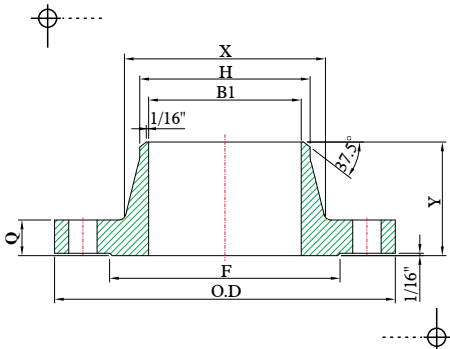

### LAP JOINT

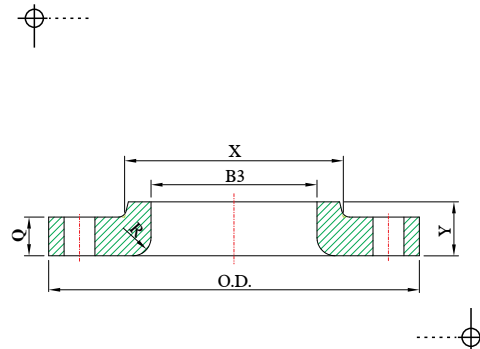

### SLIP-ON

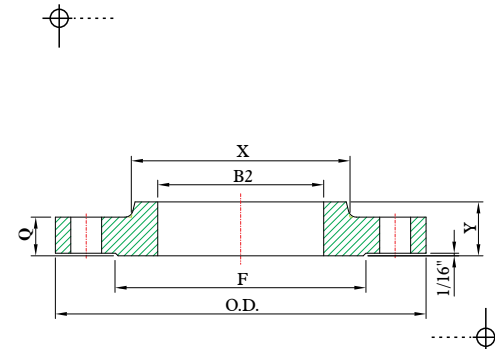

## DIMENSIONS

unit : inch

NOM. PIPE SIZE	FLANGE DIAMETER (O.D.)	FLANGE THICKNESS (Q) MIN. (1)	HUB DIA. AT BASE (X)	RAISED FACE DIA. (F)	HUB DIA. AT WELDING POINT (H)	BORE DIAMETER (B)			COUNTER BORE OF THREADED FLANGE (C) MIN.	DEPTH OF SOCKET (D)	LENGTH THROUGH HUB (Y)		
						(B1) WELDING NECK AND SOCKET WELD (2)	(B2) SLIP-ON AND SOCKET WELD MIN.	(B3) LAP JOINT MIN.			WELDING NECK	SLIP-ON SOCKET WELD AND THREADED	LAP JOINT
1/2	3.75	0.56	1.50	1.38	0.84	0.62	0.88	0.90	0.93	0.38	2.06	0.88	0.88
3/4	4.62	0.62	1.88	1.69	1.05	0.82	1.09	1.11	1.14	0.44	2.25	1.00	1.00
1	4.88	0.69	2.12	2.00	1.32	1.05	1.36	1.38	1.41	0.50	2.44	1.06	1.06
1 1/4	5.25	0.75	2.50	2.50	1.66	1.38	1.70	1.72	1.75	0.56	2.56	1.06	1.06
1 1/2	6.12	0.81	2.75	2.88	1.90	1.61	1.95	1.97	1.99	0.62	2.69	1.19	1.19
2	6.50	0.88	3.31	3.62	2.38	2.07	2.44	2.46	2.50	0.69	2.75	1.31	1.31
2 1/2	7.50	1.00	3.94	4.12	2.88	2.47	2.94	2.97	3.00	0.75	3.00	1.50	1.50
3	8.25	1.12	4.62	5.00	3.50	3.07	3.57	3.60	3.63	0.81	3.12	1.69	1.69
3 1/2	9.00	1.19	5.25	5.50	4.00	3.55	4.07	4.10	4.13	-	3.19	1.75	1.75
4	10.00	1.25	5.75	6.19	4.50	4.03	4.57	4.60	4.63	-	3.38	1.88	1.88
5	11.00	1.38	7.00	7.31	5.56	5.05	5.66	5.69	5.69	-	3.88	2.00	2.00
6	12.50	1.44	8.12	8.50	6.63	6.07	6.72	6.75	6.75	-	3.88	2.06	2.06
8	15.00	1.62	10.25	10.62	8.63	7.98	8.72	8.75	8.75	-	4.38	2.44	2.44
10	17.50	1.88	12.62	12.75	10.75	10.02	10.88	10.92	10.88	-	4.62	2.62	3.75
12	20.50	2.00	14.75	15.00	12.75	12.00	12.88	12.92	12.94	-	5.12	2.88	4.00
14	23.00	2.12	16.75	16.25	14.00	13.25	14.14	14.18	14.19	-	5.62	3.00	4.38
16	25.50	2.25	19.00	18.50	16.00	15.25	16.16	16.19	16.19	-	5.75	3.25	4.75
18	28.00	2.38	21.00	21.00	18.00	17.25	18.18	18.20	18.19	-	6.25	3.50	5.12
20	30.50	2.50	23.12	23.00	20.00	19.25	20.20	20.25	20.19	-	6.38	3.75	5.50
24	36.00	2.75	27.62	27.25	24.00	23.25	24.25	24.25	24.19	-	6.62	4.19	6.00

# ASTM A182 FLANGES ANSI B16.5

## CLASS 300 STAINLESS STEEL FLANGES ANSI B16.5

### THREADED

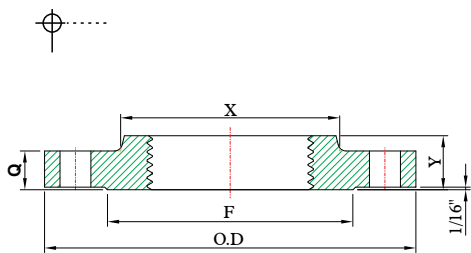

### BLIND

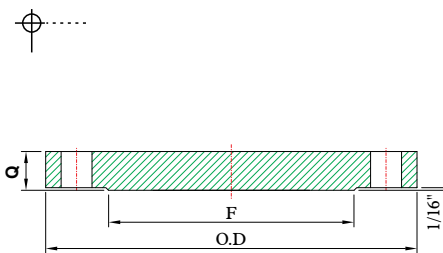

### SOCKET WELD

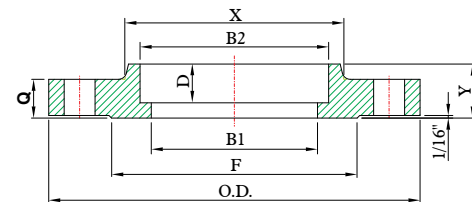

## DIMENSIONS

unit : inch

NOM. PIPE SIZE	MIN. THREAD LENGTH	RADIUS (R) LAP JOINT	DRILLING			BOLTING			
			DIAMETER OF BOLT CIRCLE	NO. OF HOLES	DIA. OF HOLES	DIA. OF BOLTS	STUD BOLT LENGTH		
							MACHINE BOLT LENGTH	Raised Face .06"	Ring Joint
1/2	0.62	0.12	2.62	4	0.62	1/2	2.25	2.75	3.00
3/4	0.62	0.12	3.25	4	0.75	5/8	2.50	3.00	3.50
1	0.69	0.12	3.50	4	0.75	5/8	2.75	3.25	3.75
1 1/4	0.81	0.19	3.88	4	0.75	5/8	2.75	3.25	3.75
1 1/2	0.88	0.25	4.50	4	0.88	3/4	3.00	3.75	4.25
2	1.00	0.31	5.00	8	0.75	5/8	3.00	3.50	4.25
2 1/2	1.12	0.31	5.88	8	0.88	3/4	3.50	4.00	4.75
3	1.19	0.38	6.62	8	0.88	3/4	3.75	4.25	5.00
3 1/2	1.25	0.38	7.25	8	0.88	3/4	3.75	4.50	5.25
4	1.31	0.44	7.88	8	0.88	5/8	4.00	4.50	5.25
5	1.44	0.50	9.25	8	0.88	3/4	4.25	4.75	5.50
6	1.56	0.50	10.62	12	0.75	3/4	4.25	5.00	5.75
8	1.75	0.50	13.00	12	0.88	7/8	4.75	5.50	6.25
10	1.94	0.50	15.25	16	1.00	1	5.50	6.25	7.00
12	2.19	0.50	17.25	16	1.00	1 1/8	6.00	6.75	7.50
14	2.25	0.50	20.25	20	1.12	1 1/8	6.25	7.00	7.75
16	2.50	0.50	22.50	20	1.12	1 1/4	6.50	7.50	8.25
18	2.69	0.50	24.75	24	1.25	1 1/4	6.75	7.75	8.50
20	2.88	0.50	27.00	24	1.25	1 1/4	7.25	8.25	9.00
24	3.25	0.50	32.00	24	1.38	1 1/2	8.00	9.25	10.25

NOM. PIPE SIZE	APPROXIMATE WEIGHT EACH— POUNDS ±			
	WELDING NECK	SLIP-ON. SOCKET WELD AND THREADED	LAP JOINT	BLIND
1/2	2	2	2	2
3/4	3	3	3	3
1	4	3	3	3
1 1/4	5	4	4	4
1 1/2	7	6	6	6
2	9	7	7	8
2 1/2	12	10	10	12
3	15	13	13	16
3 1/2	18	17	17	21
4	25	22	22	27
5	32	28	28	35
6	42	39	39	50
8	67	58	58	81
10	91	81	91	125
12	140	115	140	185
14	180	165	190	250
16	250	190	250	295
18	320	250	295	395
20	400	315	370	505
24	580	475	550	790

# ASTM A182 FLANGES ANSI B16.5

## CLASS 600 STAINLESS STEEL FLANGES ANSI B16.5

### WELDING NECK

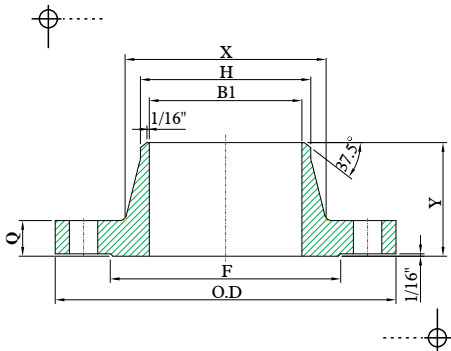

### LAP JOINT

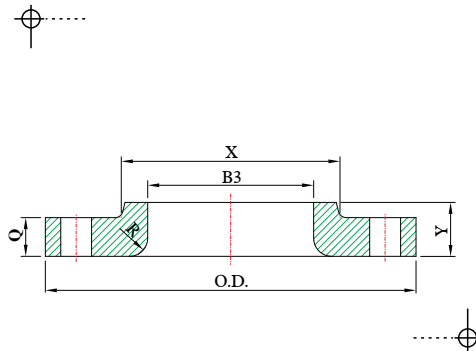

### SLIP-ON

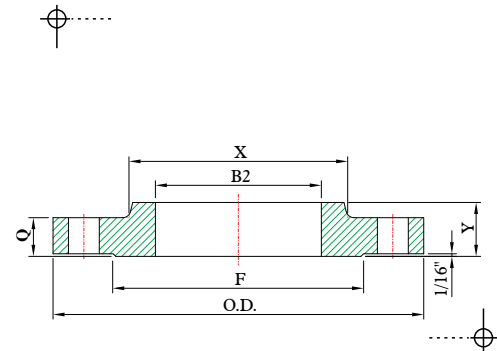

## DIMENSIONS

unit : inch

NOM. PIPE SIZE	FLANGE DIAMETER (O.D.)	FLANGE THICKNESS (Q) MIN. (1)	HUB DIA. AT BASE (X)	RAISED FACE DIA. (F)	HUB DIA. AT WELDING POINT (H)	BORE DIAMETER (B)			COUNTER BORE OF THREADED FLANGE (C) MIN.	DEPTH OF SOCKET (D)	LENGTH THROUGH HUB (Y)		
						(B1) WELDING NECK AND SOCKET WELD (2)	(B2) SLIP-ON AND SOCKET WELD MIN.	(B3) LAP JOINT MIN.			WELDING NECK	SLIP-ON SOCKET WELD AND THREADED	LAP JOINT
1/2	3.75	0.56	1.50	1.38	0.84		0.88	0.90	0.93	0.38	2.06	0.88	0.88
3/4	4.62	0.62	1.88	1.69	1.05		1.09	1.11	1.14	0.44	2.25	1.00	1.00
1	4.88	0.69	2.12	2.00	1.32		1.36	1.38	1.41	0.50	2.44	1.06	1.06
1 1/4	5.25	0.81	2.50	2.50	1.66		1.70	1.72	1.75	0.56	2.62	1.12	1.12
1 1/2	6.12	0.88	2.75	2.88	1.90		1.95	1.97	1.99	0.62	2.75	1.25	1.25
2	6.50	1.00	3.31	3.62	2.38		2.44	2.46	2.50	0.69	2.88	1.44	1.44
2 1/2	7.50	1.12	3.94	4.12	2.88		2.94	2.97	3.00	0.75	3.12	1.62	1.62
3	8.25	1.25	4.62	5.00	3.50		3.57	3.60	3.63	0.81	3.25	1.81	1.81
3 1/2	9.00	1.38	5.25	5.50	4.00		4.07	4.10	4.13	-	3.38	1.94	1.94
4	10.75	1.50	6.00	6.19	4.50		4.57	4.60	4.63	-	4.00	2.12	2.12
5	13.00	1.75	7.44	7.31	5.56		5.66	5.69	5.69	-	4.50	2.38	2.38
6	14.00	1.88	8.75	8.50	6.63		6.72	6.75	6.75	-	4.62	2.62	2.62
8	16.50	2.19	10.75	10.62	8.63		8.72	8.75	8.75	-	5.25	3.00	3.00
10	20.00	2.50	13.50	12.75	10.75		10.88	10.92	10.88	-	6.00	3.38	4.38
12	22.00	2.62	15.75	15.00	12.75		12.88	12.92	12.94	-	6.12	3.62	4.62
14	23.75	2.75	17.00	16.25	14.00		14.14	14.18	14.19	-	6.50	3.69	5.00
16	27.00	3.00	19.50	18.50	16.00		16.16	16.19	16.19	-	7.00	4.19	5.50
18	29.25	3.25	21.50	21.00	18.00		18.18	18.20	18.19	-	7.25	4.62	6.00
20	32.00	3.50	24.00	23.00	20.00		20.20	20.25	20.19	-	7.50	5.00	6.50
24	37.00	4.00	28.25	27.25	24.00		24.25	24.25	24.19	-	8.00	5.50	7.25

TO BE SPECIFIED BY PURCHASER

# ASTM A182 FLANGES ANSI B16.5

## CLASS 600 STAINLESS STEEL FLANGES ANSI B16.5

### THREADED

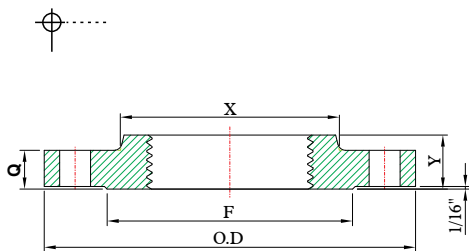

### BLIND

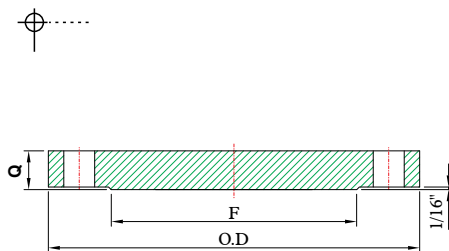

### SOCKET WELD

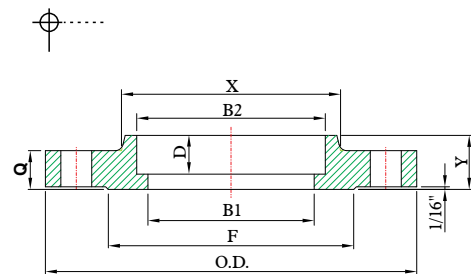

## DIMENSIONS

unit : inch

NOM. PIPE SIZE	MIN. THREAD LENGTH	RADIUS (R) LAP JOINT	DRILLING			BOLTING			
			DIAMETER OF BOLT CIRCLE	NO. OF HOLES	DIA. OF HOLES	DIA. OF BOLTS	MACHINE BOLT LENGTH	STUD BOLT LENGTH	
								Raised Face .06"	Ring Joint
1/2	0.62	0.12	2.62	4	0.62	1/2	3.25	3.00	3.00
3/4	0.62	0.12	3.25	4	0.75	5/8	3.50	3.25	3.50
1	0.69	0.12	3.50	4	0.75	5/8	3.75	3.50	3.75
1 1/4	0.81	0.19	3.88	4	0.75	5/8	4.00	3.75	4.00
1 1/2	0.88	0.25	4.50	4	0.88	3/4	4.25	4.00	4.25
2	1.12	0.31	5.00	8	0.75	5/8	4.25	4.00	4.50
2 1/2	1.25	0.31	5.88	8	0.88	3/4	4.75	4.50	5.00
3	1.38	0.38	6.62	8	0.88	3/4	5.00	4.75	5.25
3 1/2	1.56	0.38	7.25	8	1.00	7/8	5.50	5.25	5.75
4	1.62	0.44	8.50	8	1.00	7/8	5.75	5.50	6.00
5	1.88	0.44	10.50	8	1.12	1	6.50	6.25	6.75
6	2.00	0.50	11.50	12	1.12	1	6.75	6.50	7.00
8	2.25	0.50	13.75	12	1.25	1 1/8	7.75	7.50	7.75
10	2.56	0.50	17.00	16	1.38	1 1/4	8.50	8.25	8.75
12	2.75	0.50	19.25	20	1.38	1 1/4	8.75	8.50	9.00
14	2.88	0.50	20.75	20	1.50	1 3/8	9.25	9.00	9.50
16	3.06	0.50	23.75	20	1.62	1 1/2	10.00	9.75	10.25
18	3.12	0.50	25.75	20	1.75	1 5/8	10.75	10.50	11.00
20	3.25	0.50	28.50	24	1.75	1 5/8	11.50	11.25	11.75
24	3.62	0.50	33.00	24	2.00	1 7/8	13.00	12.75	13.25

NOM. PIPE SIZE	APPROXIMATE WEIGHT EACH— POUNDS ±			
	WELDING NECK	SLIP-ON. SOCKET WELD AND THREADED	LAP JOINT	BLIND
1/2	2	2	2	2
3/4	4	3	3	3
1	4	4	4	4
1 1/4	6	5	5	5
1 1/2	8	7	7	8
2	12	9	9	10
2 1/2	18	13	12	15
3	23	16	15	20
3 1/2	26	21	20	29
4	42	37	36	41
5	68	63	61	68
6	81	80	78	86
8	120	115	110	140
10	190	170	170	230
12	225	200	200	295
14	280	230	250	355
16	390	330	365	495
18	475	400	435	630
20	590	510	570	810
24	830	730	810	1250